

# スピードコントローラー(SCS)

## SPEED CONTROLLER

### ■ 特長

Features

- 業界初、標準化で大好評  
First in this field, highly reputed.
- 高性能、低価格  
High performance, low price.
- ワンタッチ継手内臓  
With built-in one-touch operation joint.



### ■ 仕様

Specifications

使用流体 Fluid used	空気 Air
使用圧力 Working pressure	0~1MPa(10kgf/cm <sup>2</sup> )
使用温度 Working temperature	-10~60℃(凍結なきこと) (Not to be frozen)

### ■ 推奨締付けトルク

Recommended Tightening Torque

ねじサイズ Screw (JIS B0203)	締付トルク(N・m) Tightening torque(N・m)
M5	0.5~1.0
R(PT)1/8	7~9
R(PT)1/4	12~14
R(PT)3/8	22~24

### ■ 型番表示方法

How to Designate

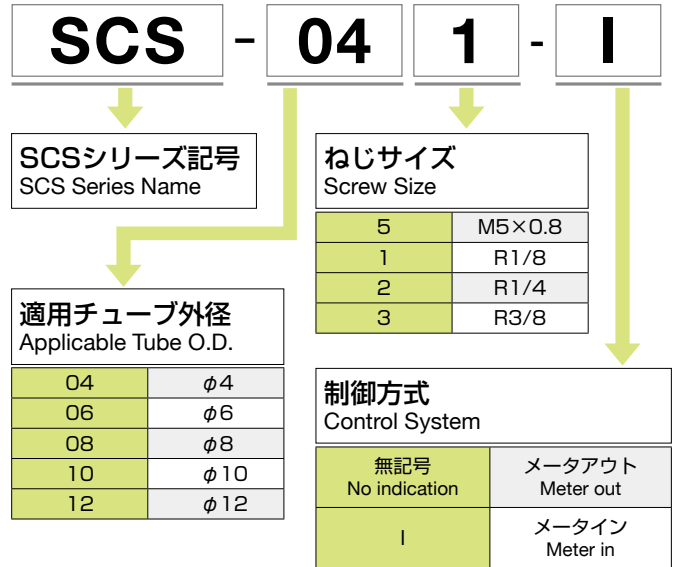

### ■ 外形寸法

External Dimension

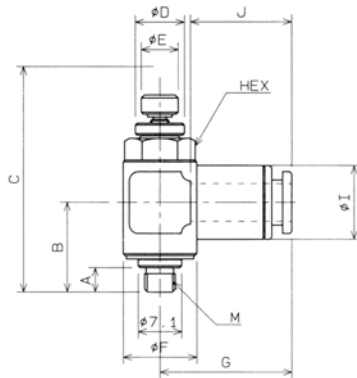

SCS-045・065

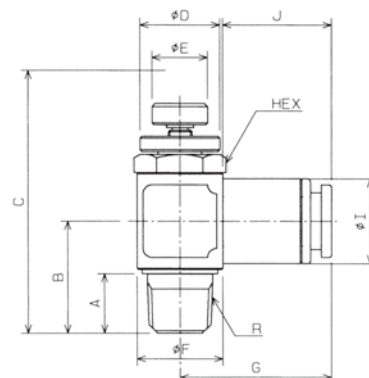

SCS-041~123

(unit : mm)

型番 Model No.	適用チューブ外径φ Applicable tube O.D.	接続ねじ Connecting screw R(M)	A	B	C		φD	φE	φF	G	HEX	φI	J	有効断面積(mm <sup>2</sup> ) Effective cross section		質量 (g) Mass										
					Max	Min								自由流 Free flow	制御流 Control flow											
SCS-045	4	M5×0.8	4	15	36.7	32.1	8	6	12	21	10	12	16	1.5	1.5	26.93										
SCS-065	6									22.5			17.5	1.5	1.5	25.81										
SCS-041	4	1/8	10	19	43.4	37.9	13	9	14	23	13	14	16	3.2	3.2	42.09										
SCS-061	6									24.5			17.5	4	3.6	41.5										
SCS-081	8									26			19	4	3.6	39.73										
SCS-062	6									1/4			13	24	53.3	47.1	16	12	17	26	16	17	17.5	7	7	76.08
SCS-082	8																			27.5			19	8	7	75
SCS-102	10																			30			21.5	8	7	72.53
SCS-083	8	3/8	14	28	61.6	55.1	19	14	22	29.5	19	22	19	15	14	138.7										
SCS-103	10									32			21.5	16	15	140.01										
SCS-123	12									33.5			23	16	15	135.72										

■ 構造図・部品材質  
Internal Construction, Part Materials

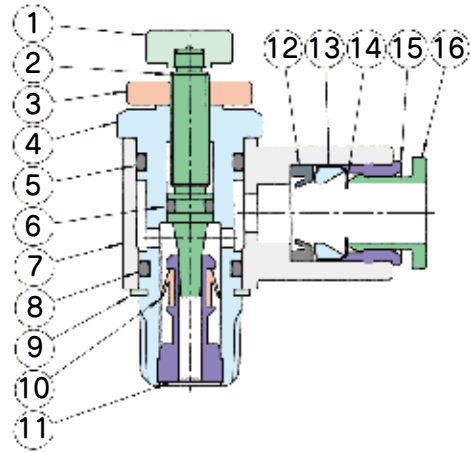
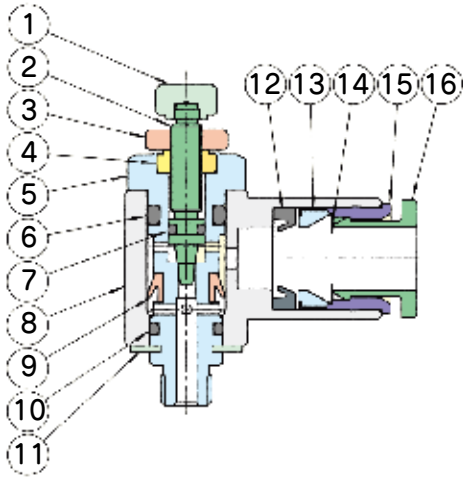

No.	名称 Name	材質 Materials
①	ハンドル Handle	SUS316
②	スピンドル Spindle	SUS316
③	ロックナット Lock Nut	SUS316
④	グランドナット Gland Nut	SUS316
⑤	回転軸 Revolving Shaft	SUS316
⑥	Oリング O Ring	FKM
⑦	Oリング O Ring	FKM
⑧	回転体 Revolving Body	SUS316
⑨	Vパッキン V Packing	HNBR
⑩	Oリング O Ring	FKM
⑪	Eリング E Ring	SUS
⑫	パッキン Packing	FKM
⑬	チャックホルダー Chuck Holder	SUS316
⑭	チャック Chuck	SUS301
⑮	アウターリング Outer Ring	SUS316
⑯	プッシュリング Push Ring	SUS316

No.	名称 Name	材質 Materials
①	ハンドル Handle	SUS316
②	スピンドル Spindle	SUS316
③	ロックナット Lock Nut	SUS316
④	回転軸 Revolving Shaft	SUS316
⑤	Oリング O Ring	FKM
⑥	Oリング O Ring	FKM
⑦	回転体 Revolving Body	SUS316
⑧	Oリング O Ring	FKM
⑨	Eリング E Ring	SUS
⑩	Vパッキン V Packing	HNBR
⑪	チェック部 Check Unit	SUS316
⑫	パッキン Packing	FKM
⑬	チャックホルダー Chuck Holder	SUS316
⑭	チャック Chuck	SUS301
⑮	アウターリング Outer Ring	SUS316
⑯	プッシュリング Push Ring	SUS316

■ 流量特性  
Flow Characteristics

●SCS-045/065

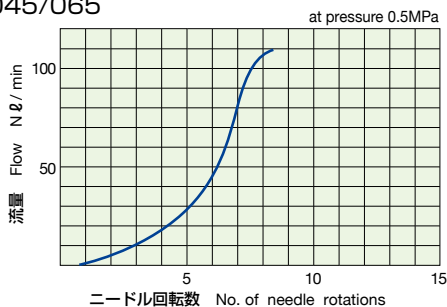

●SCS-041/061/081

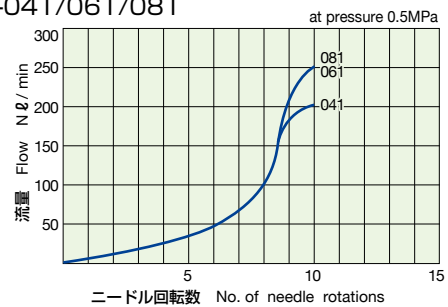

●SCS-062/082/102

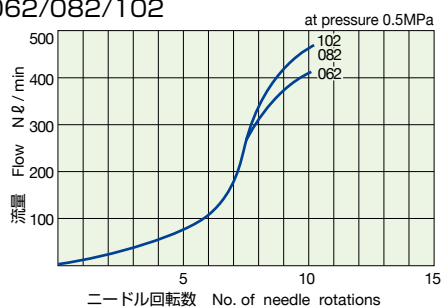

●SCS-083/103/123

